



National High School Rodeo Shooting Sports Rules/Guidelines

Revised February 1, 2022

Introduction

The NHSRA established shooting sports as part of the activities scheduled for National Finals Rodeo(s) in 2005 in partnership with the NRA (National Rifle Association). No longer supported by the NRA, this program continues to thrive and in January 2022 became an event within National High School Rodeo Association that will be offered in all states/provinces where interest is shown.

Section 1: The Essentials

Section 2: Rifle Shooting Sports Program

Section 3: Shotgun Shooting Sports Program

Section 4: Other Awards

Section 5: Range Operation

Section 6: Training Courses Available

Section 7: Grants

Section 8: Light Rifle Rules for NHSRA

Section 9: Trap Rules for NHSRA

Section 10: Shooting Sports Dress Code (for National Finals Events)

Section 1: Qualified Supervision- Roles and Responsibilities

The National High School Rodeo Association is comprised of 44 states, 5 Canadian Provinces, Australia, Mexico and New Zealand. Each state, province and country have a National Director as well as an elected or appointed board.

Each state, province or country interested in forming shooting sports teams should appoint or elect a Shooting Sports Coordinator. Contact information for this person must be reported to the National Shooting Sports Coordinator in the Denver, Colorado office. Information regarding changes, updates and rules are communicated from the National Office to the individual Shooting Sports Coordinators for each state, province or country as well as to National Directors and State/Provincial Secretaries.

State/Provincial/Country Shooting Sports Coordinator

- Must be 21 years of age or older
- NRA certified instructor for one or both disciplines offered in the NHSRA (*recommended*)
- Current NRA Range Safety Officer certification (*recommended*)

NRA Range Safety Officer (Recommended)

- Twenty-one years of age or older and holds current NRA range safety officer credentials
- In charge of the firing line at any time it is in operation
- May not leave the firing line any time it is in operation
- May or may not be the same person as the State/Provincial/Country Shooting Sports Coordinator

Section 2: Rifle Shooting Sports Program

Purpose: To introduce NHSRA members into shooting sports programs

Rifles: **Junior High and High School Division-** Any .22 caliber rimfire .22 short, .22 long, or .22 long rifle with not less than a 2-pound trigger pull, and which weighs not more than 8 ½ pounds when equipped with sights. **Telescopic sights must be set at 10 power or less.** No portion of the rifle or any attachment to the rifle shall extend more than 3 inches beyond the rear of the shooter's shoulder.

Ammunition: Rimfire cartridges commercially catalogued as the “.22 Short, “.22 Long, or “.22 Long Rifle which have an over-all length not more than 1.1 inches and loaded with a lead or alloy bullet of not larger than .23-inch diameter. *Hollow point, tracer, incendiary or explosive bullets are specifically excluded from ammunition authorized for match use.*

Range: A NHSRA approved range (approved by the State/Provincial Shooting Sports Coordinator), public or private range or club for cartridge firing rifles.

Training: *Recommended:* NRA Rifle FIRST Steps (3 hours) or NRA Basics of Rifle Shooting Course (8 hours) taught by an NRA Rifle Instructor or NRA/USA Shooting/CMP certified rifle coach. If contestant has completed Hunter's Safety training, this training would not be necessary. **Please note: This training is RECOMMENDED, not REQUIRED.**

Safety: Eye and ear protection is REQUIRED.

Range Supervision: A NHSRA approved coordinator or certified range safety officer is to directly supervise all live fire on the range.

Ratio: One approved NHSRA coordinator or range safety officer or rifle instructor to eight shooters. The number of range safety officers at the National Finals events is 1/per 3 shooters on the firing line.

Course: Refer to NHSRA Small Bore Rifle Rules.

Events: A rifle shooting competition MUST be submitted and approved by the National Office on a Rodeo Approval Form a minimum of 30 days prior to the event.

Section 3: Shotgun Shooting Sports Program

Purpose: To introduce NHSRA members into shooting sports programs

Shotguns: High School Division Only- Youth or adult size 20, 16 or 12-gauge shotguns may be used.

Ammunition: Correct ammunition for the shotgun being fired. *Tracer, armor-piercing and explosive ammo are not allowed.*

Range: A NHSRA approved range (approved by the State/Provincial Shooting Sports Coordinator), public or private range or club.

Training: *Recommended* NRA Shotgun FIRST Steps (3 hours) or NRA Basics of Shotgun Shooting Course (8 hours) taught by an NRA Shotgun Instructor or NRA/USA Shooting/CMP certified shotgun coach. If contestant has completed Hunter's Safety training, they would not be required to take this training. ***Please note: This training is RECOMMENDED, not REQUIRED.***

Safety: Eye and ear protection is REQUIRED.

Range Supervision: A NHSRA approved coordinator or certified range safety officer is to directly supervise all live fire on the range.

Ratio: One approved NHSRA coordinator or range safety officer or shotgun instructor per 5 shooters.

Course: Refer to NHSRA Shotgun Rules.

Events: A shotgun shooting competition MUST be submitted and approved by the National Office on a Rodeo Approval Form a minimum of 30 days prior to the event.

Section 4: Other Awards

[For Shooting Sports Members in General, not necessarily affiliated with NHSRA]

NRA Marksmanship Qualification Program. From a young shooter's first BB gun to sophisticated air rifles, shotguns, muzzleloaders, pistols and rifles, the NRA Marksmanship Qualification Program offers shooters a self-paced training platform to develop their shooting skills. It's a drill. We set the standards and you meet the challenge! Progression is self-paced, and scores are challenging but attainable. Performance is measured against established par scores and any shooter who meets or exceeds those scores is entitled to the corresponding recognition awards for that rating. For more information visit: <https://mqp.nra.org>.

National Rifle Association Youth Education Summit. Since the program's inception in 1996, more than 850 students have graduated from Y.E.S. and over \$500,000 in scholarships has been awarded. Scholarships totaling over \$55,000 will be awarded at this summit. For more information, please go to: <https://yes.nra.org>.

NRA Youth Wildlife Art Contest The George Montgomery/NRA Youth Wildlife Art Contest offers young artists interested in hunting and wildlife an outlet to use their creative talent, practice artistic techniques, and refine wildlife identification skills through the creation of original works. This contest encourages youth to nurture their interest for the visual arts, hunting, and wildlife conservation. It also reinforces the positive effects of hunting and wildlife conservation with the public at large.

Students grades 1 through 12 (including home-schooled children) are eligible to enter and all entries must portray North American game birds or animals that may be legally hunted or trapped. Artists have the chance to win thousands of dollars in prizes! For more information, visit <https://artcontest.nra.org/>.

Building the Next Generation of Hunters NRA's Youth Hunter Education Challenge (YHEC) provides a fun environment for kids 18 and under to improve their hunting, marksmanship and safety skills. Through its simulated hunting situations, live fire exercises, educational and responsibility events, YHEC helps build upon skills learned in basic hunter education courses and encourages safer, lifelong hunting habits. From rifle, bow and muzzleloader shooting at life-sized targets, to wildlife identification, map and compass orienteering and more, YHEC participants can get hands-on training in eight skill areas, giving them expertise in all methods of take and all types of game. For more information, please visit: <https://yhec.nra.org/>.

Shooting Sports Coach Development The NRA Coach Education Program offers multi-level training for coaches of the competitive shooting sports in partnership with USA Shooting, the Civilian Marksmanship Program, the Amateur Trapshooting Association, the National Skeet Shooting Association and the National Sporting Clays Association. Separate coach training courses are available for rifle, shotgun, pistol and high-power rifle. It is our goal to provide every coach with the tools to be successful. The NRA is committed to creating a positive environment in which coaches, athletes, parents, officials and fans work together to achieve our mission in the shooting community. For more information, please visit: <https://coach.nra.org/>.

Rocky Mountain Elk Foundation: Conservation Awards & Scholarships

The Wildlife Leadership Awards (WLA) were established to recognize, encourage and promote leadership among future wildlife management professionals. The WLA grants scholarships to college juniors and seniors chosen for their dedication to wildlife conservation.

Each spring, the RMEF recognizes outstanding wildlife science college students through our scholarship program, the Wildlife Leadership Awards (WLA). Established to recognize, encourage and promote leadership among future wildlife management professionals, the program awards scholarships to college juniors and seniors chosen for their leadership ability, dedication to wildlife conservation and scholastic achievements. Awards include a \$5,000 scholarship and one-year RMEF membership.

WLA encourages young adults to pursue a career in conservation (wildlife management in particular) and provides a means for them to acquire the in-depth knowledge and experiences necessary to cement their commitment to the cause and become leaders in their field.

For more information, go to rmef.org/rmef-kids

SECTION 5: RANGE OPERATION

General Equipment Common to all Shooting Disciplines:

Range Safety Flag. As an indicator that the range is active, the range safety flag is to be displayed in a prominent place (on a flagpole) visible to approaching spectators and shooters. It is recommended that the flag be of bright color and prominent size. This flag should be removed at the end of the shooting session (or when the range is “cold”).

Eye and Hearing Protection. Each shooter **MUST** wear hearing and eye protection appropriate for each shooting discipline. **It is recommended that spectators in immediate, designated areas also wear protection.**

Empty-chamber indicator. An added safety measure while storing or transporting firearms (or when the firearm is unattended) is a visual empty-chamber indicator. A simple method is a piece of high-visibility heavy monofilament trimmer line, cut approximately 12 inches longer than the barrel of the firearm. When inserted in the barrel, approximately 6 inches of the line should be visible at both the muzzle and the breech.

Ammunition Control. Only the number of rounds of ammunition required to complete the competition should be allowed on the firing line.

First-Aid Kit. It is recommended that a first-aid kit be readily available for the range. It should be well stocked and include items appropriate for potential injuries unique to the specific shooting sports venue. Assistance with preparing these kits is usually provided by local EMT or hospital personnel. Check on this availability in your local community.

Emergency Communications Device. If cell phone coverage at your venue is not available, make sure there is a landline that can be used in case of emergency. Prepare a list in advance of any medical service numbers you may need specific to your exact location.

Safe Gun Handling. Each firearm must be treated as if it were loaded. With that in mind, the following universal rules of safe gun handling **MUST** be followed at all times:

- **Always** keep the firearm pointed in a safe direction
- **Always** keep your finger off the trigger and outside the trigger guard until you are instructed to shoot
- **Always** keep your firearm unloaded until instructed to load/shoot
- **Know** your target and what is beyond it
- **Be familiar with the safe operation of your firearm**
- **Always use the correct ammunition for your firearm**
- **Unattended firearms should not be accessible to unauthorized persons**

SECTION 6: TRAINING COURSES

National Rifle Association Training *

***NRA Certified Rifle Instructor.** NRA Certified Instructors are individuals who are 21 years old or older. The NRA Instructor courses take experienced shooters and teach them to “teach” shooting using the NRA methodology and standards. The course is 14 hours and includes classroom and range activities with student teaching, evaluation and testing. The course is conducted by an NRA Training Counselor.

***NRA Certified Shotgun Instructor.** The NRA shotgun instructor course is 11 hours and includes classroom and range activities with student teaching, evaluation and testing. The course is conducted by an NRA Training Counselor.

***NRA Certified Range Safety Officer.** The NRA basic Range Safety Officer training is 9 hours and includes classroom and range activities with student teaching, evaluation and testing. The course is conducted by an NRA Chief Range Safety Officer or NRA Training Counselor. **For more information go to: <https://rso.nra.org/>**

***NRA Chief Range Safety Officer.** The NRA Chief Range Safety Officer training is approximately 8 hours and includes classroom and range activities with student teaching, evaluation and testing. The course is conducted by an NRA Training Counselor. **For more information go to: <https://rso.nra.org/>**

***NRA Training Counselor.** Qualified, experienced, certified instructors may apply for appointment as a training counselor to recruit and train new instructors to teach basic firearms training courses. To be eligible, they must:

- Be a member of the NRA
- Have at least 2 years of experience teaching discipline-specific NRA basic courses, conducting a minimum of 5 basic firearms courses with a total of 25 students.
- Attend a training counselor workshop and receive the endorsement of the NRA training counselor trainer.

***NRA Coach Education Program.** The coach education program under the Education and Training Division of the NRA offers both basic and advanced technical and tactical skills coach training schools for rifle, pistol, shotgun and high-power rifle along with training camps and clinics. Training reflects the latest in coaching philosophy and presentation methodology along with the most up-to-date techniques and competition tactics to help you and your team achieve your goals.

For information on all Education Programs offered by the NRA, please visit: <https://coach.nra.org/> for more information.

***NOTE- Due to ITAR Regulations, NRA training can only be delivered to US Citizens. Please see specific information for your Province/Country for training provided in your locale.**

SECTION 7: GRANTS

***NOT ASSOCIATED WITH NHSRA**

NRA Foundation Grants. For more than two decades, The NRA Foundation has served the needs of freedom-loving Americans across this great nation. We continue to teach freedom through programs that instill knowledge about our nation's great history. We build partnerships with leaders in our communities and provide grants that are instrumental in funding programs that support our shared vision.

Since our establishment in 1990, we've exceeded more than \$300 million in funding through more than 38,000 grants in support of the shooting sports. These grants provide essential funding that benefits programs such as youth education, law enforcement training, hunter education, conservation, firearms and marksmanship training and safety, and much more.

If your eligible organization or program is in need of funding assistance, you're invited to apply for a grant through The NRA Foundation. Two types of grants are available: General Grants are offered for supplies, equipment and consumables; Range Grants are offered to improve a range facility, for projects such as berm work, classroom, pavilion, road or trap machine improvements. Visit <https://www.nrafoundation.org/grants/frequently-asked-questions/> for more information.

Friends of NRA Banquets. Friends of NRA banquets are known for three things- fun, fellowship, and fundraising. For more information, please visit: <http://www.friendsofnra.org/>.

SECTION 8: NHSRA RIFLE RULEBOOK

National High School Rodeo Small Bore Rifle Rules

REVISED February 1, 2022

NATIONAL HIGH SCHOOL RODEO ASSOCIATION

Official Rules for Small bore Rifle Matches

SAFETY IS YOUR BUSINESS! READ THE RULES

These rules provide for the efficient and orderly operation of a competition. But *that's not all*. Many local range regulations exist for one reason alone SAFETY. Others serve a dual purpose, smooth range operation and SAFETY. It's your responsibility as a competitor or as a competition official to be familiar with the rules and to know the meaning behind those which are safety oriented.

NRA GUN SAFETY RULES (Adopted by the NHSRA)

The fundamental NRA rules for safe gun handling are:

- Always keep the gun pointed in a safe direction.
- Always keep your finger off the trigger until ready to shoot.
- Always keep the gun unloaded until ready to use.

When using or storing a gun, always follow these NRA (Adopted by the NHSRA) rules:

- Be sure the gun is safe to operate.
- Know how to safely use the gun.
- Use only the correct ammunition for your gun.
- Know your target and what is beyond.
- Wear eye and ear protection as appropriate.
- Never use alcohol or drugs before or while shooting.
- Store guns so they are not accessible to unauthorized persons.

Be aware that certain types of guns and many shooting activities require additional safety precautions. To learn more about gun safety, enroll in an NRA safety training or basic marksmanship course, NRA hunter clinic or state hunter education class.

1. NHSRA COMPETITION

1.0 NSHRA Competition - NHSRA Competition is a competition which is authorized by the National High School Rodeo Association. The program, range facilities and officials must comply with standards established by NHSRA and must be approved by the National Office by submitting a Rodeo Approval form 30 days prior to the event via the State/Provincial Secretary.

1.1 NHSRA Sanctioned Events - A Sanctioned Event is an event that has been approved by the National Office. Such matches must be conducted by a NHSRA affiliated organization.

1.2 Types of NHSRA Matches

(a) Match - A complete event as indicated in the schedule for the awarding of certain specific prizes. A match may consist of one or several stages.

(b) Stage - A portion of a match which consists of one or more strings fired in one position, distance, time allowance, or target.

(c) Unsquadded Individual Match- A match in which the competitor is not assigned a definite relay or target. The competitor reports to the official registration area within the time limits specified on the official posting board and is then assigned to a target and a relay in which to fire. For the National Finals event(s), report times will be listed on the official Draw Posting Board prior to the event.

2. ELIGIBILITY OF COMPETITORS

Eligibility of Competitors – Competitors qualify for the National Finals events at the State/Provincial Finals.

INDIVIDUALS

2.1 Members of the National High School Rodeo Association - Any individual member of the Association or Junior High Division of the Association in good standing.

3. EQUIPMENT AND AMMUNITION

This section defines authorized equipment. Where alternative types of equipment are shown, the least restrictive conditions apply unless the tournament programs set forth limitations.

3.1 Light Rifle - Any .22 caliber rimfire .22 short, .22 long, or .22 long rifle with not less than a 2-pound trigger pull, and which weighs no more than 8 ½ pounds when equipped with sights. No portion of the rifle or any attachment to the rifle shall extend more than 3 inches beyond the rear of the shooter's shoulder. The same rifle must be used throughout all stages of any one match (except aggregate) except in the case of a malfunction or disabled rifle when the competitor may change rifles with permission of the Chief Range Officer.

3.2 Trigger Guard - A rifle must be equipped with an effective trigger guard. Lack of a trigger guard constitutes an unsafe rifle.

3.3 Sights-

(a) Metallic

(1) **Non-corrective:** Any sighting system, constructed of metal or equivalent, which provides a method of aiming or aligning 2 separate but visible sights, or reference points mounted on the rifle, including tube sights and non-magnifying color filters.

(2) **Corrective:** Same as (1), except that a lens or system of lenses, not containing an aiming reference or reticle at the focal plane of any such lens or system of lenses, may be included in such system.

(b) Telescopic - Any sighting system which includes a lens or system of lenses and an aiming reference or reticle at the focal plane of a lens or system of lenses. Telescopic sights must be set at 10 power or less.

(c) Any - Any sight without restriction as to material or construction.

(d) Prohibited - Any sighting device programmed to activate the firing mechanism is prohibited.

(e) Any sight/scope used cannot be set to anything above 10x and when attached to the rifle, and the rifle MUST meet rifle weight requirement.

3.4 Shooting Kits - The shooting kit may not be placed forward of the shooter's forward shoulder on the firing line, except that in the standing position a shooting kit, table, or stand may be used as a rifle rest between shots. The shooting kit, table, or stand may not be of such size and construction as to interfere with shooters on adjacent firing points or to constitute a wind break.

3.5 Personal Wind Indicators - Are not permitted and will be provided by the event coordinators.

3.6 Ground Cloth - Ground cloth may be used providing it is not constructed or used in a manner to provide artificial rest or support.

3.7 Gloves- Gloves may be worn which do not form an artificial support.

3.8 Shooting Coats - Are not permitted.

3.9 Shooting Trousers - Are not permitted.

3.10 Padding - Shoulder pads, sling pads and elbow pads may be worn while shooting, provided they are constructed so as not to provide artificial support.

3.11 Slings –Unless otherwise specified in the conditions of the match by the Arena Director, the rifle sling may be used in the prone and kneeling positions only. There are two types of slings are allowed (unless otherwise specified by the Arena Director).

A. Single point sling of the arm cuff type consisting of a quick detach at the forearm or the hand stop. Sling cuff will be attached to the upper arm with sling running on the outside or inside of the forearm. At no time will the sling be between the palm of the hand and the stock / body of rifle.

B. Two-point sling, consisting of two attachment points one at the forearm or hand stop, the second point will be at the buttstock of the rifle on the bottom of the stock. The sling will be positioned from the rear attachment point across the upper part of contestant's body, around the outside of the upper arm, sling will then proceed forward on the outside or inside of forearm. At no time will the sling be between the palm of the hand and the stock / body of the rifle. At no time will the arm be placed between the separate straps of the sling to act as an arm cuff.

3.12 Kneeling Roll - A cylindrical cushion for shooting in the kneeling position; maximum dimensions will be 9.84 inches long (25 cm) and 7.08 inches in diameter (18 cm) and made of soft and flexible material.

3.13 Butt plates and hook - A butt hook projecting more than 153 mm (6.02 inches) past the rear of a line, which is perpendicular to a line drawn through the axis of the bore of the rifle, and which is tangent to the deepest part of the butt plate depression that normally rests against the shoulder. It must have a total

outside length around any curve or bend of not more than 178 mm (7.01 inches).

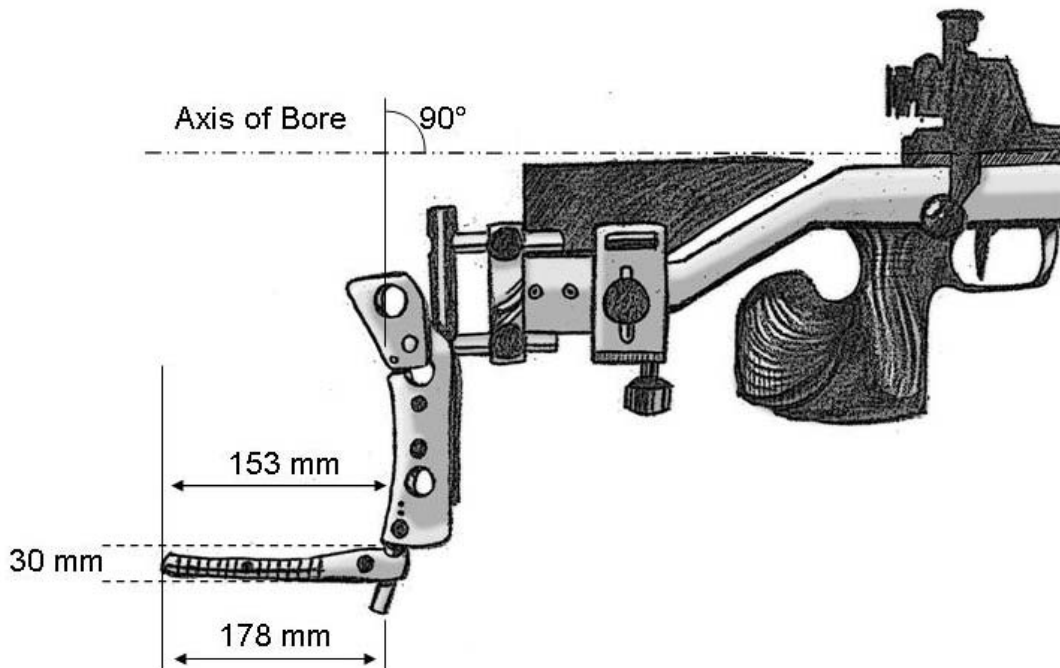

3.14 Release Triggers - Triggers which function on release are prohibited.

3.15 Ammunition - Rimfire cartridges commercially catalogued as the “.22 Short, “.22 Long, or “.22 Long Rifle which have an over-all length not more than 1.1 inches and loaded with a lead or alloy bullet of not larger than .23-inch diameter. *Hollow point, tracer, incendiary or explosive bullets are specifically excluded from ammunition authorized for match use.*

3.16 General - All devices or equipment which may facilitate shooting, and which are not mentioned in these Rules, and which are contrary to the spirit of these Rules and Regulations, are forbidden. The Arena Director or CRSO shall have the right to examine a shooter’s equipment or apparel. The responsibility shall be upon the competitor to submit questionable equipment and apparel for official inspection and approval in sufficient time prior to the beginning of a match so that it will not inconvenience either the competitor or the official.

3.17 Eye Protection- All competitors and other personnel in the immediate vicinity of the range complex must wear eye protection devices.

3.18 Ear Protection - All competitors and other personnel in the immediate vicinity of the range complex must wear hearing protection devices. Only sound reducing devices may be worn by competitors forward of the ready line.

3.19 Empty Chamber Indicator (ECI) - A small bore ECI is required in all small-bore rifle competitions to indicate that the chamber is empty. The ECI must be continuous from chamber to muzzle visible at both ends.

3.2 Audible Timing Devices - Audible timing devices are allowed.

3.21 Electronic Devices-Radios, tape recorders, or any type of sound producing, or communications systems are prohibited forward of the ready line except hearing aids and those devices necessary for range control.

4. TARGETS

4.1 Official Targets- NRA Official Targets will be used. 50 Yard A23/5. 3 shots may be fired on each record bulls eye.

5. POSITIONS

Positions - The positions for use in a match shall be stated in the program under conditions of the match and shall be in accord with the definitions of positions prescribed in this section.

No portion of the shooter's body *or equipment* may rest upon or touch the ground in advance of the firing line.

5.1 The Ground - All references to "the ground" in the following position Rules are to be construed as applying to the surface of the firing point, floor, such as shooting mats, or platforms as are customarily used on shooting ranges.

5.2 Artificial Support - Any supporting surface except the ground not specifically authorized for use in the Rules for the position prescribed. Digging or use of elbow or heel holes at the firing points or the use of depressions which form artificial support for the elbows, arms, or legs is prohibited. Use of artificial support including back braces or use of magazine or vertical handle on the firearm are prohibited except as individually authorized by NHSRA for a physically handicapped shooter.

5.3 Position of Rifle Butt-In all positions, except standing (Rule 5.6), the butt of the rifle must be held against the front of the shoulder on the outside of the shirt and must not touch the ground.

5.4 Prone - Body extended on the ground, head toward the target. The rifle will be supported by both hands and one shoulder only. No portion of the arms below the elbows shall rest upon the ground or any artificial support, nor may any portion of the rifle or body rest against any artificial support. The forearm supporting the rifle shall form an angle with the line from the point of elbow contact to the target of not less than 30°. (Measured through the axis of the forearm.)

5.5 Kneeling - Buttocks clear of the ground but may rest on one foot. The rifle will be supported by both hands and one shoulder only. The elbow of the arm supporting the rifle rests on the knee or leg. The elbow of the trigger arm will be free from all support. One knee must be touching the ground or shooting mat. The shooter may be on all, partially on, or all off the shooting mat. A roll as described in Rule 3.12 may be placed under the instep provided the foot is placed toe down at an angle not greater than 45 degrees from the vertical. Only the trousers and underclothing may be worn between the shooter's buttocks and heel. No other article may not be placed between these two points. If the kneeling roll is not used, the foot may be positioned at any angle, to include placing the side of the foot and the lower leg in contact with the ground.

5.6 Standing - The shooter shall stand free with both feet on the ground or at his mat without any other support. The rifle shall be held with both hands and the shoulder (upper right chest) or the upper arm near the shoulder, the cheek and the part of the chest next to the right shoulder. However, the rifle must not be supported by the jacket or chest beyond the area of the right shoulder and right chest. The left upper arm and elbow may be supported on the chest or on the hip. The use of the sling is prohibited for all rifles. (Left-handed shooters reverse these descriptions)

5.7 Illegal - Anyone found using an illegal position shall be warned once and given an opportunity to correct his/her position. If the same person continues to use an illegal position or reverts to it, that person shall be penalized according to the provision of Rule 9.20.

5.8 The elbow is defined as 4 inches from the point of the arm when bent.

6. RANGE STANDARDS

6.1 Firing Line - The firing line is immediately in front of the several firing points. All ranges are measured from this firing line to the face of the targets when targets are hung in their proper position in front of the backstop.

6.2 Firing Point - That part of the range provided for the competitor immediately in the rear of the firing line from which firing takes place. Each firing point is numbered to correspond with the target frames. Each firing point should have a maximum width of five feet and a minimum of 3'9" (at the discretion of the Arena Director).

6.4 Distance

(a) Rifle range is 50 yards.

6.5 Illumination-Artificial illumination of ranges is authorized.

6.6 Target Numbers - Target frames will be numbered on alternating background of contrasting color. The number will be large enough to be identified under ordinary conditions with normal vision. The numbers should be at least nine inches high and must correspond with firing point numbers.

7. COURSE OF FIRE

7.1 Course of Fire - Targets will be changed after each 12 shots. The number of shots on record bulls at each position are 50 yards, 3 shots.

7.2 NHSRA 3-Position- 1st Round

<i>Distance</i>	<i>Target</i>	<i>No. of Shots per Match</i>	<i>per Bull</i>
50 Yards	A23/5	12 in each position Prone, Standing and Kneeling	3

7.3 NHSRA 3-Position- Short Round

The top 20 Shooters from the 1st round will compete in the Short Round the following day. All shooters should compete at the same time (with the same conditions). Placing in the competition would be determined on the aggregate scores from the 1st Round and the Short Round.

<i>Distance</i>	<i>Target</i>	<i>No. of Shots per Match</i>	<i>per Bull</i>
50 Yards	A23/5	12 in each position Prone, Standing and Kneeling	3

8. TIME LIMITS

8.1 Computing Time - Time is not checked on each shot. The time allowance is computed for a complete stage (including sighting shots when specified) on the basis of the specified number of shots multiplied by the allowances per shot. The Chief Range Safety Officer may terminate any relay before completion of the full time allowed, if all competitors in that relay have completed firing. Time allowed, but not used, does not carry over to another string or stage.

8.2 Time Allowance:

One minute per record shot prone (including optional sighter shots) and kneeling. 1 ½ minutes per shot standing.

The competitor will be allowed a maximum of an additional 5 minutes for a target change.

8.3 Passage of Time- Range Officers will not voluntarily warn competitors of the passage of time. Competitors may inquire of Range Officers as to the time remaining before expiration of the time limit. The request for time and the response shall be given in a tone which will not disturb other competitors.

9. COMPETITION REGULATIONS

9.1 Changing Rifles - No competitor will exchange his/her rifle or the stock of his/her rifle during the firing of any single or multiple stage match unless it has become disabled and has been so designated by the Chief Range Safety Officer. For the purpose of this Rule, the firing of a match is considered to have started when the competitor has fired his first record shot. Claim that a rifle is disabled must be made immediately. All shots fired up to the time that the claim is made will stand as part of the official score. *Changing butt plate assemblies does not constitute changing rifles.*

9.2 Sighting Shots - Sighting shots are permitted ONLY in the prone position of the match. Each competitor is allowed 5 sighting shots. **(Time for relay is inclusive of these shots; no additional time is allowed).** They will only be fired upon the command "COMMENCE FIRING".

9.2.1 Misplaced Sighting Shots

When the first sighting shot hits below an imaginary or transcribed line midway between the sighter and record bullseyes (not touching the line with aid of scoring gauge), the competitor will inform the Range Officer of the location of such shot before firing another shot on the target card: the Range Officer will indicate to the Arena Director or Chief Range Safety Officer the value and location of the bullet hole. No such claim will be allowed after the competitor has fired more than one shot on the target card. After the first sighting shot any additional shot below an imaginary or transcribed line midway between the sighter and record bullseye (not touching the line with aid of scoring gauge), will be considered a record shot.

9.3 Defective Cartridge - A defective cartridge is one:

- (a) which has such evident structural defect as to cause misfire or cause a rifle to fail to function
- (b) which does not fire
- (c) from which the bullet has not left the barrel. (No claim for a defective cartridge shall be allowed if bullet has left the barrel except in the incident of a ruptured case. The Range Officer will indicate to the Arena Director or Chief Range Safety Officer the value and location of the bullet hole.) (For procedure in case of a defective cartridge see Rule 10.9. For refiring privileges see Rule 9.14.)

9.5 Disabled Rifle - Any rifle which cannot be properly aimed or safely fired may be declared disabled. Sights improperly adjusted do not constitute a disabled rifle. A rifle once declared disabled by the Range Officer shall not be used again for competition firing until the defect has been corrected and the rifle has been ruled as safe by the Chief Range Officer. (For procedure in case of a disabled rifle see Rule 10.9. For refiring privileges see Rule 9.14.)

9.6 Malfunction - Failure of the rifle to function properly due to mechanical defects or to defective ammunition. Functional failures, due to improper manual operation are not to be considered as malfunctions. (For procedure in case of a malfunction see Rule 10.9. For refiring privileges see Rule 9.14.)

9.7 Weighing Triggers – All rifles presented for inspection MUST have an ECI inserted as rifles are presented for inspection. If the competitors' rifle does not include this safety indicator upon presentation for inspection, the competitor will be asked to leave the area to insert one. The ECI must be continuous from chamber to muzzle visible at both ends. Triggers will be weighed with official NRA trigger test weights or by any other calibrated method at the discretion of the Arena Director. Failure of the trigger to meet the trigger pull requirements shall disqualify the competitor in matches previously fired. While the trigger pull is being weighed, the rifle shall be held with barrel perpendicular to the horizontal surface on which test weight is supported. The rod or hook of test weight shall rest on the lowest point of the curve in curved triggers or on a point approximately ½ inch from the lower end of

straight triggers. To pass the weight test, a weight of the correct number of pounds shall be lifted by the rifle trigger while in the cocked position and while all safety devices are in firing positions, from the horizontal surface on which it is resting, until the weight hangs free and without releasing the trigger. Failure of the trigger to pass the weight test is the competitor's responsibility. **During the firearm check in period, the firearm safety officer will attempt to pass the firearm for both weight and trigger pull. They will attempt to qualify the firearm a maximum of three times at this time. If the firearm will not pass both requirements, the contestant will have the opportunity to make adjustments and have the firearm rechecked. If the firearm will not pass after the adjustments are made, the firearm safety officer may disqualify the firearm for the competition.**

9.8 Competitor's Position - A competitor will take his position on the firing line as directed by the Chief Range Safety Officer. No portion of the shooter's body *or equipment* may rest upon or touch the ground in advance of the firing line.

9.9 Coaching Prohibited in Individual Matches - Coaching is prohibited in all individual matches. If a competitor wishes to speak with his coach or leader, he must unload his firearm, leave it in a safe condition on the firing line and leave the firing line to confer with coach or leader, being careful not to disturb other competitors. **Competitor must first have permission from the CRSO to confer with coach or leader.**

9.10 Matches Not Complete:

Individual matches not complete-When a match or stage is not completed by all competitors in accordance with the tournament schedule, the match or stage may be rescheduled or cancelled. Any match or stage which has been completed by all competitors will not be re-fired.

9.11 Interference - With the exception of competitors actually firing and such range personnel as may be necessary, the firing points and lines will be kept clear at all times. Competitors will not be permitted to interfere with the handling of targets by range personnel.

9.14 Re-firing

(a) No competitor will fire more than one score for the same award except as provided in the competition rules or in accordance with Rule 9.10.

(b) No competitor will be allowed more than one re-fire because of the defective cartridge, disabled rifle or malfunction.

9.15 Cross Fire and Excessive Hits - No competitor will deliberately fire on the wrong target nor fire more than the required number of shots, including hits on some other competitor's target card.

9.16 Disorderly Conduct - Disorderly conduct or intoxication is strictly prohibited at the range *complex* and anyone guilty of same will be expelled from the range *complex*.

9.17 Willful Destruction Of Range Equipment - No competitor shall cause any range equipment to become damaged through a deliberate act and anyone guilty of same will be expelled, without a warning, from the range. Expelled competitors will be disqualified from the competition.

9.18 Refusal to Obey - No person will refuse to obey instructions of the Arena Director, Chief Range Safety Officer, Range Officers or of any other officer of the competition, if instructions are given in the proper conduct of his office.

9.19 Evasion of Rules - No competitor will evade nor attempt to evade nor be an accessory to the evasion of any of the conditions of a match as prescribed in the in these rules. Refusal of a competitor or Officials to give testimony regarding facts known to him concerning violations or attempted violations of these rules will constitute being an accessory to the violation or attempted violation and may be subject to disciplinary action.

9.20 Penalties/Disqualifications - In cases of infringement and contravention of the regulations or of the instructions of range officers by an individual shooter, team shooter or non-firing team member, the following penalties may be imposed upon the individual competitor by the Arena Director, Chief Range Safety Officer, Range Officer or other competition official certified by NHSRA.:

1. Warning
2. Deduction of points from the score
3. Disqualification

In case of infringement of the regulations:

(a) A warning may be given so that the competitor may have the opportunity to correct the fault. In the case of a serious violation of safety regulations, the Chief Range Safety Officer, Arena Director or other competition official certified by NHSRA has the authority to impose immediate disqualification on the competitor.

(b) If the competitor does not correct the fault before the next shot, 10 points shall be deducted from his score.

(c) For a repeated infringement, the competitor may be disqualified.

(d) A warning to the competitor must be expressed in such terms as will leave no doubt that it is an official warning. A warning to the competitor, whenever it is possible, should be given so as not to disturb him while firing a shot, unless the infringement concerns safety, in which case the competitor shall be warned immediately.

(e) If a competitor continues to handle his firearm in a dangerous manner, or continues to violate any of the safety regulations, he may be disqualified.

(f) If the Arena Director, Chief Range Safety Officer, Range Officer or other competition official certified by the NHSRA is of the opinion that the competitor has attempted to intentionally circumvent the rules or disturb other competitors in an unsportsmanlike manner, he may be warned, then penalized by the deduction of 10 points from his score and may be disqualified.

(g) If the Arena Director, Chief Range Safety Officer, Range Officer or other competition official certified by the NHSRA considers that the competitor is holding up the procedure unnecessarily, with the intention of gaining unfair advantage, he may be warned, then penalized by having 10 points may be deducted from his score or may be disqualified.

(h) The discharge of any firearm anyplace other than the firing line, or the firing line prior to the shooters being placed in the preparation period, will result in disqualification and expulsion from the competition. If a firearm is discharged while the shooters are in the preparation period prior to the command **LOAD**, it will result in the competitor being disqualified.

(i) Any competitor placing an unfired cartridge in the chamber, on the loading ramp or in the magazine before the command "load", will be warned on the first violation and disqualified for the second violation.

10. RANGE COMMANDS, CONTROL AND OPERATIONS

10.1 Discipline - The safety of competitors, range personnel and spectators requires continuous attention by all to the careful handling of firearms and caution in moving about the range. Self-discipline is necessary on the part of all. Where such self-discipline is lacking it is the duty of the range personnel to enforce discipline and the duty of competitors to assist in such enforcement.

Under no circumstances shall firing commence or continue on a range where an unsafe condition exists.

10.1.1 Actions Open - Unless the rifle is cased, the action must remain open at all times and the ECI inserted in the chamber. The ECI must be continuous from chamber to muzzle visible at both ends. No competitor will aim toward the targets until the proper command is given. No rifle will be handled in any manner to violate any rule of safety.

10.1.2 Rifles Unloaded - Rifles will not be loaded until the competitor has taken position at his firing point, rifles pointed toward the targets and the command "LOAD" has been given.

10.1.3 Loaded Rifles - No loaded cartridge will be inserted into the rifle nor placed on the loading ramp except at the firing point and under the command "LOAD". The muzzle of the rifle will be pointed in the direction of the targets and will be forward of the firing line until the rifle is discharged or unloaded.

10.1.4(a) Cease Firing - All shooters will immediately stop firing upon the command "Cease Firing". Actions will remain open and an ECI inserted in the chamber. The ECI must be continuous from chamber to muzzle visible at both ends.

"Cease" is the preparatory part of the command and "Firing" is the action part of the command. NO shot should be fired after the word "Firing" is spoken.

10.1.4(b) Commence Firing - All shooters may start firing upon the command "Commence Firing" as the timing of the string is started with this command.

"Commence" is the preparatory part of the command and "Firing" is the action part of the command. NO shot will be fired before the word "Firing" is spoken.

10.1.5 Not Ready - It is the duty of competitor(s) to notify the Range Officer if not ready to fire at the time the Chief Range Officer asks, "IS THE LINE READY?" Failure of competitor(s) to notify the Range Officer that he is not ready means they forfeit their right to refire.

NOTE: 1. If a competitor is not ready through no fault of his own, he will be given an opportunity to explain. If satisfactory, the competitor will be permitted to refire at a later time or simply allowed to fire with his relay and given additional time to make up for time lost.

2. If the competitor is not ready because of his own actions, he will be required to fire within the appropriate time on his appropriate relay.

10.3.1 Preparation Period - (The preparation period will begin only after the shooters have been given time to bring their rifles to the line.) In all cases competitors will be allowed a minimum of 3 minutes to take their places at their firing points and prepare to fire at the beginning of each match, after the firing point has been cleared by the preceding competitor.

Range officials may allow a reasonable period of time (5 minutes) for equipment set-up before the beginning of the three-minute preparation period.

10.3.2 Interrupted Fire - If firing is halted for two minutes or more, a preparation period of a minimum of one minute will be given, and one minute will be added to the firing time remaining.

10.4 Policing Range - It is the duty of competitors to police the firing points after the completion of each Stage, unless otherwise directed. The Range Officers will supervise such policing and will see that the firing points are kept clean.

10.5 Competitors may Score - Competitors will act as scorers when requested to do so by the Arena Director or Chief Range Officer, except that no competitor will score his own target.

10.6 Repeating Commands - A Range Officer will repeat the Chief Range Officer's commands only when those commands cannot be clearly heard by competitors under his supervision.

10.7 Firing Line Procedures and Commands - When ready to start the firing of a match the Chief Range Officer commands "**RELAY ON THE FIRING LINE.**" Competitors in that relay may set up their equipment on their assigned firing points but will not bring their rifle to the firing line until called to do so by the Chief Range Officer. After the down range area is clear, targets are hung and all shooters and match personnel are behind the firing line the Chief Range Officer commands, "**RELAY ... YOU MAY BRING YOUR RIFLES TO THE LINE, ECIs MUST BE INSERTED IN YOUR CHAMBERS.**"

The Chief Range Officer states, "**YOUR ____ MINUTE PREPARATION PERIOD STARTS NOW.**"

At the end of the preparation period the Chief Range Officer states, "**YOUR PREPARATION PERIOD HAS ENDED.**" After ascertaining that the range is clear, he proceeds with the range firing commands. The Chief Range Officer then asks, "**IS THE LINE READY?**" Any competitor who is not ready or whose target is in bad order, will immediately raise his arm and call, "**NOT READY ON TARGET....**" The Chief Range Officer will immediately state "**THE LINE IS NOT READY**", and the Range Officer will immediately investigate the difficulty and assist in correcting it.

When the difficulty has been corrected, the Chief Range Officer calls, "**THE LINE IS READY.**"

When the Chief Range Officer asks, "**IS THE LINE READY?**" and the line is ready, he then calls, "**THE LINE IS READY.**"

If the size of the line requires it for safety, the Chief Range Officer will state the following: "**READY ON THE RIGHT, READY ON THE LEFT, READY ON THE FIRING LINE.**"

The Chief Range Officer then commands "**LOAD.**" Rifle chambers may be loaded.

The Chief Range Officer then commands "**COMMENCE FIRING.**" At the latter command he starts his stopwatch or makes note of the time and at the end of the time limit commands "**CEASE FIRING-BOLTS OPEN.**" All rifle chambers and magazines are unloaded, and competitors leave the firing line with the actions of their rifles open.

Shooters are reminded that there will be no handling of firearms forward of the ready line while shooters are down range.

Before competitors are allowed down range the Chief Range Officer should ask "**IS THE LINE CLEAR?**" This means that all rifles on the line are unloaded, and all bolts are open. Upon receiving confirmation from the Line Officers that all rifles are clear, say "**THE LINE IS CLEAR.**" Additional instructions are proper at this time such as "**GO FORWARD AND CHANGE TARGETS**" or "**REMOVE YOUR EQUIPMENT FROM THE LINE FOR THE NEXT RELAY.**"

Succeeding relays are handled in like manner.

Range Officers will immediately command "**CEASE FIRING—BOLTS OPEN**" if any incident occurs which indicates possible injury to some living thing should firing continue. In all other cases commands will originate with the Chief Range Officer.

Should a target blow out of the frame or otherwise become unserviceable the Range Officer will report the condition immediately to the Chief Range Officer who will issue such commands and directions as seem advisable to him.

10.7.1 Range Alibis – Re-fires are allowed through faulty or improper range procedure and or weather such as: Targets of a relay rendered un-scoreable or unshootable because of extreme weather conditions (wind/rain).

10.9 Procedure in Case of Defective Cartridge, Disabled Rifle or Malfunction - If a cartridge fails to fire or a rifle fails to function the competitor will call the Range Officer. The Range Officer, when satisfied that there is a defective cartridge, disabled rifle, or malfunction, will permit the competitor to replace the unfired cartridge or clear the jam and continue firing. Additional time may be allowed each competitor, equal to the time lost because of the defective cartridge, disabled rifle or malfunction. It is not required that the Range Officer attempt to fire a cartridge before it is declared defective.

11. COMPETITION OFFICIALS

Officials will be thoroughly familiar with conditions of the program and with National High School Rodeo Association Rules.

11.1 Arena Director - The Arena Director is the official primarily responsible for the efficient conduct of the entire tournament. He may change match and firing conditions from those shown in the program, provided an announcement is posted for the information of all competitors, and that such changes are not contrary to current NHSRA Rules. The Arena Director is also directly responsible for the efficient operation of the range and scoring and for the safety and proper discipline of all tournament operating personnel, competitors and spectators. Instructions from the Arena Director for the operation of the tournament will be complied with by all persons on the range. The Arena Director will use the best judgment at all times. His behavior and decisions must be characterized by absolute impartiality, firmness, courtesy and complete awareness. In the application of these Rules the Arena Director will confer with the NHSRA Shooting Sports Coordinator or Committee on any doubtful point and will be guided by their decision.

11.2 Coordinator - The National Coordinator is not an administrative or operating official and is not responsible for the behavior or efficiency of either range or scoring personnel. It is the responsibility of the Coordinator to properly interpret and apply all NHSRA Rules. Except in an emergency involving the safety of personnel or property, the Coordinator will not give instruction directly to tournament operating personnel but will give all such instructions through the Arena Director. In the event of a disagreement between Tournament Officials, the Coordinator shall prevail at the match with recourse only to the National High School Rodeo Association Shooting Sports Committee. It is the duty of the Coordinator to render a complete report to the NHSRA covering all phases of the tournament. The Coordinator may disqualify all or any portion of the score, if, in the Coordinator's opinion, the conditions warrant such action.

11.4 Chief Range Safety Officer – NHSRA Chief Range Safety Officers are people who possess the knowledge, skills, and attitude essential to organizing, conducting, and supervising safe shooting activities and range operations. CRSO personnel will give instruction and clarification on rules and proper conduct to both competitors and other Range Safety Officer personnel on the firing line.

11.5 Range Safety Officer - The Range Safety Officer (RSO) supervises shooting activities as prescribed by the range Standard Operation Procedures (SOPs), NHSRA Rulebook and instruction provided by the Chief Range Safety Officer.

11.6 Student Event Director - The Student Event Directors are elected by the finals contestants entered in the shooting sports competition. The student(s) elected should only be entered in the shooting competitions only to avoid arena conflicts with rodeo events. There will be one Rifle Shooting Sports Event Director at the Junior High Finals and one Rifle Shooting Sports Event Director and one Trap Event Director at the High School Finals. **The student directors will be present during the event they are overseeing for the duration of the event and will be the first point of contact in the event of a challenge or protest by a contestant or provide an equally knowledgeable replacement for this duty.** It is the Student Event Director's responsibility to understand and follow all NHSRA Rules and Regulations, to escalate issues as they arise to the Arena Director and be present during challenge or protest resolution meetings with the contestant.

12. PHYSICALLY DISABLED SHOOTERS

12.1 Physically Disabled Shooters - A shooter who because of physical disability cannot fire from one or more of the prescribed shooting positions outlined in these Rules, or who must use special equipment when firing, is privileged to petition the NHSRA for permission to assume a special position or to use modified equipment, or both. This petition will be in the form of a written request from the person concerned to the Committee outlining in detail the reasons why the special positions must be assumed, or the special equipment must be used. The petition will be accompanied by pictures of the shooter in the position he desires approved and, if special equipment is required, the picture will show how this equipment is used. The petition and all pictures must be furnished in exact duplicate. The petition must be accompanied by a medical doctor's statement if the physical disability is not completely evident in the pictures submitted.

(a) Each petition will be reviewed by the Arena Director, the Coordinator and the NHSRA Shooting Sports Committee (if applicable). The Committee may require additional or supplementary statements, medical information or pictures. If approved, the NHSRA will issue special authorization to the individual concerned. Such authorization will have necessary pictures attached.

(b) Shooters who have received special authorization will be required to carry them when competing in competition governed by NHSRA Rules, and to present the authorization when requested by officials of the competition or by the NHSRA Coordinator.

(c) In the event of a protest involving the position or the equipment used by such a shooter, the Arena Director will compare the questioned position or equipment with the certificate and photographs presented by the shooter. If the shooter's position or equipment does not, in the opinion of the officials, conform to that authorized by the NHSRA (or if the shooter has no authorization or pictures), the protest shall be allowed, and the shooter will be required to change immediately to the position or equipment which has been approved or to an otherwise legal position or equipment.

12.2 Temporary Disability: Substitute Position - Any person who has a temporary physical disability, as substantiated by a current written medical opinion, which prevents him from using a specified position may assume the next more difficult position in lieu of that position. In this manner, kneeling may be used for prone, and standing may be used for kneeling. The Arena Director must be informed of the substitute and may require that the substitute position be demonstrated so that he may be certain it meets the definition of the appropriate rule.

13. SCORING

13.1 When to Score - Targets are scored as they are collected from the firing line. Special conditions may require other than this usual procedure.

13.2 Where to Score - Targets may be scored in the office or on the range. Scoring of targets while hanging is prohibited. Whenever targets are scored where backing cards are used, the record target and backing card shall be compared.

13.2.1 Targets as Score Cards - Targets constitute the score cards when scored and therefore must be retained in good order until the time allowed for filing challenges and protests has expired.

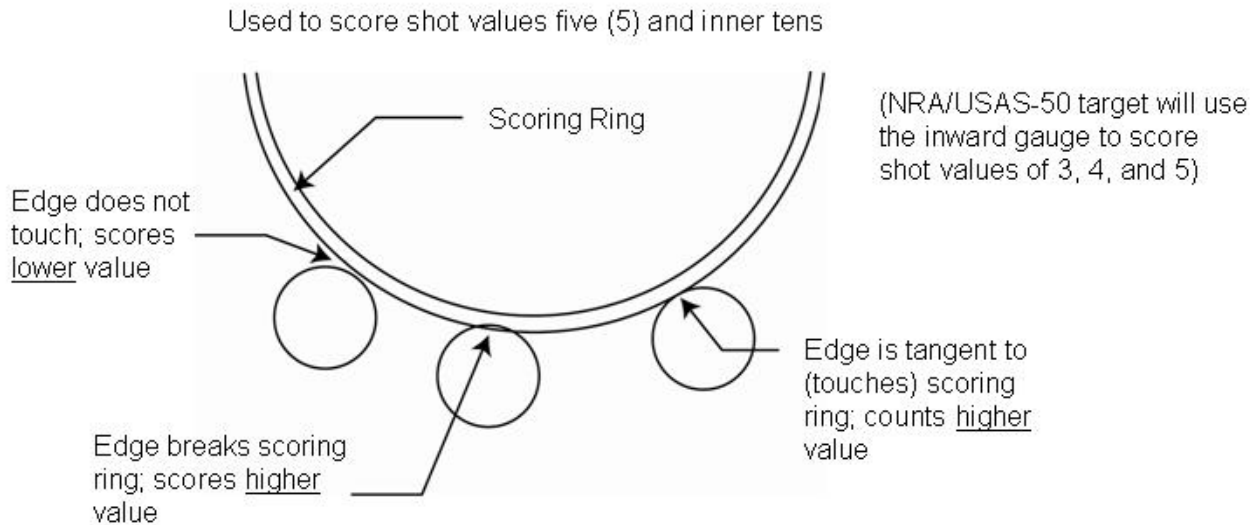

13.3 How to Score - A shot hole, the lead edge of which comes in contact with the outside of the bullseye or scoring rings of a target, is given the higher value. If a competitor fails to hit any target (shot/s outside the scoring ring) that shot will be scored as a miss (zero). A scoring gauge will be used to determine the value of close shots. Scorers must indicate on the target which shots were plugged.

(a) Inward (best edge) scoring is done as follows: The higher value will be allowed in cases where the flange on the gauge touches the scoring ring. Inward gauges must be within the following limits: .2225-.2240 inches (5.65 - 5.69 mm).

(b) *Shot groups* - When, in scoring outdoor targets, the 10 and in some cases, the 9 rings are partially obliterated by shot groups of two or more shots or when two adjacent shot holes have a connecting tear in the target paper, the plug type scoring gauge shall not be used. In such cases, the values of the shots in the partially obliterated scoring ring area shall be determined by authorized tournament scoring personnel, and the Arena Director when required, by using a scoring gauge aid. The plastic overlay is **NOT** authorized for use in determining the value of single well defined shot holes. The use of this plastic overlay scoring aid supersedes any requirement for the use of a plug-type gauge under the conditions described.

Note: Targets will be scored while in a horizontal position. The plug gauge should be inserted carefully so that no pressure is exerted to any side as this may affect the final plug position in the shot hole and, therefore, the value of the hit. Never plug a shot that is not doubtful. If two scorers cannot agree on the value of a shot, another match official will decide. To make tie breaking easier, it is suggested to score all center shots the first time the scoring team scores a target. Ties would be broken simply by comparing targets as opposed to re-scoring.

(d) *Center shots* - Those shot holes fired on targets without X-ring (A-7, A-17, A-32, A-33, A-50, and A-51) are used to break ties and rank scores. Center shots are determined as follows:

Light Rifle (A-32 target) - Any shot hole within the ten ring which, with the aid of a .22 caliber plug type scoring gauge or overlay, the flange or outer ring of which does not touch the outside edge of the ten ring.

13.3.1 Authorized Use of Plug Type Scoring Gauges - The use of the plug type gauge will be restricted to use by range operating personnel who may include the Range Officers or Arena Director, Coordinator or authorized NHSRA personnel, as appropriate to the type of tournament concerned.

13.4 Misses - Hits outside the scoring rings of the competitor's target are scored as misses.

13.5 Early or Late Shots - If any shots are fired before the command **COMMENCE FIRE**, after the command **LOAD** has been given or immediately after the command **CEASE FIRE** prior to the command **THE LINE IS SAFE**, the shots of the highest value on the target card, equal in number to those fired in error, will be scored as misses. All shots fired before or after this time see Rule 9.20(h).

13.7 Excessive Hits

Note: The term "target card" will be interpreted as applying to all record bullseyes framed at one time.

- (a) *On his own target* - If a competitor fires more than the required number of shots on a target card, he will be scored only the required number of hits of lowest value minus a penalty equal to the highest score in the target per target (not cumulative scores from the match).
- (b) *On the target of another competitor* - If a competitor fires more than the required number of shots for a target card and one or more hits are on a target other than his own, all shots on the targets of others will be brought back to the corresponding bullseye(s) on his own target and scored as outlined in Rule 13.7 (a) (excessive hits) and Rule 13.8 (cross-fires). An excessive hit fired on a target other than your own will be brought back as a miss (0).

13.8 Crossfires

- (a) Crossfires of competition shots must be scored as misses. If a shooter fires a sighting shot on the competition target of another shooter, he must be penalized by deduction of the highest score from his own score.
- (b) If a shooter fires a sighting shot on the sighting target of another shooter no penalty is incurred.
- (c) If a shooter receives a confirmed crossfire shot and it is impossible to determine which shot is his, he must be credited with the value of the highest undetermined shot.
- (d) If there are more hits on a shooter's competition target than are provided for in the program, and if it is impossible to confirm that another shooter(s) fired the shot(s), the hit(s) equal to the highest value must be nullified.
- (e) If a shooter wishes to disclaim a shot on his target, he must report this immediately to a Range Officer.
- (f) If the Range Officer confirms that the shooter did not fire the disputed shot(s), he must make the necessary entry on a Range Report the shot must be annulled.
- (g) If the Range Officer cannot confirm beyond all reasonable doubt that the shooter did not fire the disputed shot(s), the shot(s) must be credited to the shooter and must be so recorded.
- (h) The following must be considered as reasons to justify the annulment of a shot:
 - (1) If the Range Official confirms by his observation of the shooter and the target that the shooter did not fire the shot;
 - (2) If a missed shot is reported by another shooter or other Range Official at approximately the same time, and from within the neighboring two or three firing points.

13.8 Ricochets - A hole made by a ricochet bullet does not count as a hit and will not be scored.

13.9 Visible Hits and Close Groups - All hits which are clearly visible on the target card will be scored. In the case where the grouping of three or more shots is such that it is possible for a required shot or shots to have gone through the enlarged hole without leaving a mark or marks, and there is no evidence that a shot or shots have gone elsewhere than through the assigned target (a cross-fire for example), the shooter will be given the benefit of the doubt and scored hits for the required number of shots in that bullseye. If such action could place a non-visible hit or hits in either of two scoring rings, such hits shall be scored in the high value ring. Backing cards, when used, should be reviewed by scoring personnel to assist in determining the number of shots creating the group in the affected bullseye.

13.11 Scoring Altered Targets - Targets intentionally altered, or marked to benefit a shooter over other competitors, will not be scored.

14. DECISION OF TIES

14.1 Match - The term "match" as used in this section refers to all individual matches.

14.7.2 Tie Breaking for Position Matches

Aggregate Matches or any fired match consisting of multiple positions.

- (1) By the greater number center shots on targets.
- (2) By the highest-ranking score in the standing position, then kneeling and prone.
- (3) By the greater of center shots in standing.
- (4) By the highest score on the last numbered bullseye in standing.
- (5) By the greater number of center shots on the last numbered bullseye in standing.
- (6) By the highest-ranking score on each bullseye applied in inverse order from last to first in standing.
- (7) By the greater number of center shots on each bullseye applied in inverse order from last to first in standing. If still a tie, apply 3 through 6 to the kneeling position, followed by prone.

14.17 Unbreakable Ties - In case a tie cannot be ranked as provided in this section, the Arena Director will direct the awards to be given under one of the following plans:

- (a) By the firing of a complete or partial score under the original match conditions or at the longest range of the match.
- (b) By drawing lots for merchandise, trophy awards, pooling and equally dividing cash awards to which those tied may be entitled.

15. CHALLENGES AND PROTESTS

The challenge period, unless otherwise resolved during the event, will start immediately after all targets for the competition have been scored and audited. The challenge period will commence for one (1) hour after all targets have been delivered to the challenge area. *Only the competitor will be allowed in the target review area. The contestant will only be allowed to review their own target.*

ALL scored targets will be available in the designated challenge area AND MAY NOT BE REMOVED FROM THIS AREA until the challenge period is over.

Challenges can ONLY be initiated by the contestant and the contestant is the only individual who may handle his/her scored targets for initial inspection and for the duration of the challenge period.

Replugging or regauging targets will ONLY be done by authorized personnel and in full view of the contestant. Any interested party found using plug tools on their own or someone else's targets prior to the end of the challenge period, may be subject to disqualification.

Administrative errors such as mathematical errors will be corrected immediately and noted in the standings after the challenge period is over.

Challenges MUST be made in a courteous manner and in the spirit of the competition. Disparaging comments or personal accusations will not be tolerated and may result in disqualification of the contestant.

Challenges will be made using this process:

- (a) Any protest MUST go through the Student Event Director first. If not reconciled, then
- (b) The Student Event Director and the contestant will consult the Chief Range Safety Officer or Arena Director.

- (c) If not satisfied with his decision, then, state the complaint orally to the Coordinator. Such complaints or protests must be filed within 4 hours of the occurrence of the protested incident.
- (d) The Student Event Director, Chief Range Safety Officer, Arena Director and Coordinator will then make a final decision regarding the protest with a complete statement of facts and notify the contestant.

15.1 Challenges - When a competitor feels that a match fired by him/herself or by another competitor has been improperly evaluated or scored, he/she may challenge that score. Such a challenge must be made within the challenge time (*replugging or regauging is permissible*). It shall be the challenging competitor's privilege to inspect the target following the recheck.

(a) The Arena Director may at his discretion or by request, re-check any competitor's target by an administrative challenge. Such a challenge must be made before the end of the last posted challenge period of the tournament and checked by competition scorers.

(b) It shall be the responsibility of the Coordinator to state in the program, on the draw posting board or via social media the time limits within which a challenge may be made.

(c) When targets are scored, the re-check will be made by a scoring auditor (provided he has not previously scored or checked the target) or the Arena Director in that order.

(d) Fired matches are challenged by total score, not individual shots, targets or stages.

(e) Aggregate matches when challenged, only correct the addition of all fired matches.

(f) Official scores will be posted once the challenge period is over and all audit adjustments (if necessary) have been made.

15.2 Protests - A competitor may formally protest:

(a) Any injustice which he feels has been done him except the evaluation of a target, which he may challenge as outlined in Rule 15.1.

(b) Conditions under which another competitor has been permitted to fire.

(c) Equipment which another competitor has been permitted to use.

15.3 How to Protest - A protest must be initiated immediately upon the occurrence of the protested incident. Failure to comply with the following procedure will automatically void the protest:

- (e) Any protest MUST go through the Student Event Director first. If not reconciled, then
- (f) The Student Event Director and the contestant will consult the Chief Range Safety Officer or Arena Director.
- (g) If not satisfied with his decision then, state the complaint orally to the Coordinator. Such complaints or protests must be filed within 4 hours of the occurrence of the protested incident.
- (h) The Student Event Director, Chief Range Safety Officer, Arena Director and Coordinator will then make a final decision regarding the protest with a complete statement of facts and notify the contestant.

ALL PROTESTS/CHALLENGES WILL BE HANDLED BY THE SHOOTING SPORTS ARENA DIRECTORS AND STAFF AND THEIR DECISIONS WILL BE FINAL. DISPUTES IN THESE EVENTS WILL BE RESOLVED BEFORE SCORES ARE POSTED. BLATANT SAFETY VIOLATIONS CAN AND WILL RESULT IN DISQUALIFICATION. DISPUTES ARE NOT ELIGIBLE FOR EXECUTIVE COMMITTEE REVIEW. IF A CONTESTANT FEELS AS IF THEIR DISPUTE WAS NOT HANDLED

PROPERLY IN THE FIELD OR DURING THE PROTEST PERIOD, THE CONTESTANT SHOULD INFORM THEIR NATIONAL/PROVINCIAL DIRECTOR FOR CLARIFICATION.

16. COMPETITORS' DUTIES AND RESPONSIBILITIES

Note: The following competitors' duties are in addition to those specified elsewhere throughout these Rules.

16.1 Discipline - It is the duty of each competitor to sincerely cooperate with Tournament Officials in the effort to conduct a safe, efficient tournament. Competitors are expected to promptly call the attention of proper officials to any infraction of rules of safety or good sportsmanship. Failure of a competitor to cooperate in such matters or to give testimony when called upon to do so may result in said competitor being considered as an accessory to the offense.

16.2 Knowledge of Program - It is the competitor's responsibility to be familiar with the program. Officials cannot be held responsible for a competitor's failure to obtain and familiarize himself with the program.

16.3 Reporting at Firing Point - Competitors must report at their assigned firing point immediately when the relay is called by the Range Officer. The proper rifle and ammunition for that particular match must be ready and in safe firing condition. Time will not be allowed for rifle repairs, sight blacking, sight adjustments or search for missing equipment after a relay has been called to the firing line.

16.4 Timing - The timing of the firing of a stage (within the official time limit) is the competitor's responsibility. Range Officers may not announce the time during the firing but if requested will give the competitor information as to remaining time.

16.5 Loading - No competitor will load a rifle except at the firing point and after command has been given by the Chief Range Safety Officer.

16.6 Cease Firing - All rifles will be unloaded immediately upon the command **CEASE FIRING – UNLOAD AND INSERT ECI**. Actions will remain open with the ECI inserted. The ECI must be continuous from chamber to muzzle visible at both ends.

16.7 Checking Scores - It is the duty of competitors to check the Posting Board and call attention to errors within the time specified at the competition. Failure to check scores within the time limit forfeits the right to challenge.

16.8 Clearing the Firing Point - It is the competitor's duty to leave the firing point promptly at the conclusion of his relay. When leaving the firing point the rifle must be unloaded with action open and ECI inserted. The ECI must be continuous from chamber to muzzle visible at both ends.

16.9 Score Cards Must be Signed - When targets are scored on the firing line or at the target butts at the conclusion of the scoring, the scorer adds the value of the shots, places the total on the score card and signs or initials the card.

16.91 Responsibility - It shall be the competitor's responsibility, that:

- (a) All equipment meets all rules and match specifications in any match in which that equipment is to be used.
- (b) Competitor's position conforms to the rules.
- (c) Competitor has full knowledge of the rules under which that match is fired.
- (d) After due warning of any infraction of existing rules, including the improper marking of the target, that competitor shall understand that a repetition thereof shall be the subject of disqualification for that relay or
- (e) When targets are framed by the competitor, it is the competitor's responsibility that the correct target and backer for the range and position being fired are framed properly.

- (f) To ensure that his target is not altered intentionally or with special marks which benefit him in any way. Scores fired on such targets will be disqualified.
- (g) When the targets are framed by the competitor, it is the competitor's responsibility to ensure that the area between the target and firing point is clear of obstructions (weeds, wind flags, etc.) before the start of the preparation period.
- (h) It is the contestant's responsibility to remove all scored targets from the office area within one (1) day after the competition is declared final (post-challenge period) when final results have been posted. All unclaimed targets will be disposed of after 1 day.

SECTION 9: NHSRA TRAPSHOOTING RULEBOOK

National High School Rodeo Trapshooting Rules

REVISED February 1, 2022

NATIONAL HIGH SCHOOL RODEO ASSOCIATION

Official Rules for Trapshooting in NHSRA

SAFETY IS YOUR BUSINESS! READ THE RULES

These rules provide for the efficient and orderly operation of a competition. But *that's not all*. Many local range regulations exist for one reason alone SAFETY. Others serve a dual purpose, smooth range operation and SAFETY. It's your responsibility as a competitor or as a competition official to be familiar with the rules and to know the meaning behind those which are safety oriented.

NRA (Adopted by NHSRA) GUN SAFETY RULES

The fundamental rules for safe gun handling are:

- Always keep the gun pointed in a safe direction.
- Always keep your finger off the trigger until ready to shoot.
- Always keep the gun unloaded until ready to use.

When using or storing a gun, always follow these NRA (adopted by NHSRA) rules:

- Be sure the gun is safe to operate.
- Know how to safely use the gun.
- Use only the correct ammunition for your gun.
- Know your target and what is beyond.
- Wear eye and ear protection as appropriate.
- Never use alcohol or drugs before or while shooting.
- Store guns so they are not accessible to unauthorized persons.

Be aware that certain types of guns and many shooting activities require additional safety precautions. To learn more about gun safety, enroll in an NRA safety training or basic marksmanship course, NRA hunter clinic or state hunter education class.

1. NHSRA COMPETITION

1.0 NHSRA Competition - NHSRA Competition is a competition which is authorized by the National High School Rodeo Association. The program, range facilities and officials must comply with standards established by NHSRA and must be approved by the National Office by submitting a Rodeo Approval form 30 days prior to the event via the State/Provincial Secretary.

NHSRA Sanctioned Events - A Sanctioned Event is an event that has been approved by the National Office. Such matches must be conducted by a NHSRA affiliated organization.

Types of NHSRA Matches

(a) Match - A complete event as indicated in the schedule for the awarding of certain specific prizes. A match may consist of one or several stages.

(b) Stage - A portion of a match which consists of one or more strings fired in one position, distance, time allowance, or target.

(c) Unsquadded Individual Match- A match in which the competitor is not assigned a definite relay or target. The competitor reports to the official registration area within the time limits specified on the official posting board and is then assigned to a target and a relay in which to fire. For the National Finals event(s), report times will be listed on the official Draw Posting Board prior to the event.

(d) SUB-EVENTS A sub-event is any number of targets shot on any one field at one time, with one full rotation on all five (5) posts by each shooter, such as (25) 16-yard targets. An event is the total targets of a specific type such as (100) 16-yard targets. It is not necessary to change traps after each sub-event.

2. ELIGIBILITY OF COMPETITORS

Eligibility of Competitors - The conditions of a match shall prescribe the eligibility of competitors.

INDIVIDUALS

2.1 Members of the National High School Rodeo Association - Any individual member of the National High School Rodeo Association.

TEAMS

2.12 Team Representation- No individual may be a Team Captain, Coach, firing member, or alternate firing member on more than one team in any one match.

CONDUCT

2.13 Members are strongly encouraged to know the NHSRA Trapshooting Rules and abide by them for their own benefit and for the benefit of other shooters. By entering the competition, every contestant agrees to accept all official decisions and to abide by these rules.

3. EQUIPMENT AND AMMUNITION

This section defines authorized equipment. Where alternative types of equipment are shown, the least restrictive conditions apply unless the tournament programs set forth limitations.

3.1 Shotgun - A contestant cannot use: A gun with a chamber larger than 12 gauge. A contestant may not use a gun capable of chambering more than one gauge of shells at the same time. For example, chambering 12 gauge and 20-gauge shells in the same gun at the same time is prohibited. The same shotgun must be used throughout all stages of any one match (except aggregate) except in the case of a malfunction or disabled shotgun when the competitor may change shotguns with permission of the Chief Range Safety Officer or Arena Director.

3.2 Ammunition – A Contestant MAY NOT USE loads that contain nickel or copper coated shot or tracer loads. However, the use of lead, steel, bismuth, or other composite non-toxic shot materials shall be allowed. A contestant MAY NOT USE any load with a velocity greater than 1290 FPS (Feet Per Second) with maximum shot charge of 1 1/8 ounces, or 1325 FPS with a maximum shot charge of 1 ounce, or 1350 FPS with a maximum shot charge of 7/8 ounces or less, as measured in any individual shot shell. These velocities are maximum, and no individual shot shell shall exceed these limits for the designated shot charge. In addition, no load containing more than 1 1/8 ounces or any shot larger than

Number 7 1/2 can be used. Shot charges are maximum and no charge may exceed the charge amount by more than 3%. Steel shot in Number 7 will be acceptable as long as velocity criteria are the same as for lead shot shells. A contestant MAY NOT USE any shell loaded with black powder. **NO reloaded ammunition is allowed.**

3.3 Challenges - Shoot Management or any contestant may challenge the load of any other contestant. Any challenge shall be initiated so as to not disrupt the harmony of the shoot or interfere with other contestants not involved with the challenge. On receipt of a challenge management shall obtain a shell or shells from the challenged party, and if after examination, management finds the contestant violated the rule, he/she may be disqualified.

3.4 Eye Protection- All competitors and other personnel in the immediate vicinity of the range complex must wear eye protection devices.

3.5 Ear Protection - All competitors and other personnel in the immediate vicinity of the range complex must wear hearing protection devices. Only sound reducing devices may be worn by competitors forward of the ready line.

4. TRAPHOUSES AND TARGETS

4.1 Trap Machine – A trap machine which throws targets at an unknown angle shall be used.

4.2 Trap houses – Trap houses must adequately protect the trap loaders and shall not be higher than necessary for that purpose.

4.3 Posts – Posts shall be 3 yards apart on the circumference of a circle whose radius is 16 yards.

4.4 Targets – Targets should not measure more than 4 5/16 inches in diameter and not more than 1 1/8 inches in height. Weight of the target should not be less than 95 grams or more than 105 grams with an allowable variation of plus or minus 5 grams per target lot. A target lot is defined as all targets with the same production number.

5. FIRING POSITIONS AND SHOOTING ORDER

Positions - The positions for use in a match shall be stated in the program under conditions of the match and shall be in accord with the definitions of positions prescribed in this section.

5.1 There shall be five (5) firing positions (posts) numbered 1 to 5 left to right, spaced 3 yards apart and at a distance of 16 yards unless:

There are less than five (5) contestants available for the last squad.

When there are draw outs from a squad after the competition has begun and the squads are scheduled.

When in the opinion of shoot management, the harmony of the shoot may be enhanced by squadding less than five (5) contestants.

5.1.1 Squad positions for less than 5 contestants shall be as follows:

If 1 shooter, post number 2

If 2 shooters, post numbers 2 and 4

If 3 shooters, post numbers 2, 3 and 4

If 4 shooters, post numbers 2, 3, 4 and 5

5.2 Shoot management will provide pullers unless voice activated pullers are used. The puller will not throw a target unless all contestants are in their correct positions.

5.3 Rotation of shooters shall be in a clockwise direction, with the shooter from post 1 advancing to post 2 and the shooter from post 5 rotating to post 1 (or to the post dictated by the number of shooters remaining).

6. SAFETY

6.1 It is the responsibility of both the shooter and shoot management to conduct a shoot in a reasonable and safe manner.

6.2 It is shoot management's responsibility to remove/disqualify any contestant who is conducting himself/herself in an unsafe manner.

6.4 It is shoot management's responsibility to instruct the trap help in proper and safe conduct of their respective duties.

6.5 All trap help must have a flag or other warning device to warn of any person(s) entering or exiting the trap house.

6.6 Trap personnel should be instructed on the potential danger of the trap; trap throwing arm.

6.7 Movement and exposure on adjacent traps should be kept to a minimum.

6.8 The practice of tracking targets behind a shooting squad is unsafe and is not permitted.

6.9 Disorderly Conduct - Disorderly conduct or intoxication is strictly prohibited at the range *complex* and anyone guilty of same will be expelled from the range *complex*.

6.10 Failure to Fire - A gun, which for any reason fails to fire as intended, must be promptly opened without any subsequent determination by the puller/scorer of the cause of the failure to fire. In the event of a jam, the contestant will be given two (2) minutes to clear the jam. If time elapses past 2 minutes, the contestant will be scored as a failure to fire for the remainder of the round.

6.11 All guns must have the action open can contain no live or empty shells at any time, except when the shooter is on the firing line and instructed to load a shell. A break open gun's action may be closed when it is in the gun rack but must not contain a live or empty shell.

6.12 Test shots will not be permitted before a squad starts shooting and may only be fired when requested by the puller/scorer to verify an apparent gun misfire, gun malfunction or broken gun.

6.13 Contestants shall place a live shell in his/her gun only when on a post facing the traps and only when instructed to do so. Only one live shell is permitted in his/her gun at one time and empty shells must be removed before moving from one post to another. When rotating posts, the shooter will not walk in front of other contestants.

6.14 A contestant may hold his/her gun in any safe position when it is his/her turn to shoot. The contestant must in no manner interfere with the preceding shooter by raising his/her gun to point or otherwise create an observable distraction.

6.15 All guns used by contestants must be equipped, fitted and utilized so as to not eject empty shells in a manner that substantially disturbs or interferes with other contestants.

6.16 All shooters, pullers/scorers and trap personnel must wear appropriate eye and hearing protection while on the trap field. Failure to do so could result in disqualification.

6.17 The practice of resting the muzzle of the shotgun on a shooter's toe is prohibited.

7. SCORING

7.1 The “official score” is the record kept by the scorer/puller on the sheets provided by shoot management and will show in detail the scores made in the event.

7.2 The scorer will keep an accurate record of each shot of each contestant and will promptly record either “DEAD” or “LOST” by marking “/” or “X” for “dead” and “0” for “lost”. If a score sheet is marked incorrectly, it must be corrected by the scorekeeper in such a manner as to leave no doubt of the score and must be initialed by the scorekeeper. Clear notations of the word “dead” or “lost” are acceptable corrections. If the intent of the scorekeeper is not clearly demonstrated, the score must be counted as lost. The scorer will verbally call “Lost” for each shot lost by each contestant. DEAD targets will not be announced by scorekeeper.

7.2.1 A scorer will rule “LOST” when the contestant fires and fails to break the target whether missed completely or when only dust falls from it. A “Dusted Target” is a target from which there is a puff of dust but no perceptible piece is seen, it is not a dead target and contestant has not called a failure to fire OR when a whole target appears promptly after a contestant’s recognizable command and is within the legal limits of flight and the contestant does not voluntarily fire OR when an illegal target, a freak target or a target of a markedly different color is fired at and missed (contestant may refuse these types of targets, but if he/she fires at the target, the result MUST be scored) OR when a contestant voluntarily or involuntarily takes no further part in the event after firing at 1 or more targets and does not fire at all the targets in the event.

7.2.2 When the shooter is prevented by reasons beyond their control from competing the scores for that partial event will not be recorded. Example: shooters have shot 61 targets of a 100-target event when a storm stops shooting. Scores for the first 50 targets only would be reported.

7.2.3 Failure to Fire. A contestant will be allowed (2) failures to fire per “Sub-event of 25”. When the first or second failure to fire occurs, the contestant will be allowed to call for and fire at another target. Whenever a failure to fire occurs, the scorer will mark F1 and if applicable, F2 on the score sheet. Subsequent failures to fire will result in “LOST” scores recorded on the score sheet.

7.3 The scorer will distinctly announce “Lost” when a target is missed and “No Target” when no target is thrown, or a target is thrown broken. The scorer may call the result of all targets or only lost targets as directed by shoot management.

7.3.1 The scorer will rule “NO TARGET” and allow another target when an allowable “Failure to Fire” occurs OR when the target is thrown broken (regardless of the result of any shot fired) OR when a whole target appears on the call of the shooter along with target debris OR when a contestant shoots out of turn OR when two (2) contestants fire at the same target OR when the trap is sprung without any call or pull or when it is sprung at any material interval of time before or after the call of the contestant provided the contestant does not fire; if the contestant fires, the result must be scored OR when two (2) targets are thrown at the same time regardless of whether the contestant fires or not OR when an “illegal” target is thrown (a target that is not within the prescribed angle or height limits for single target shooting or what is known as a “flipper” or “freak” target which is a target that may have slipped out of or was not properly placed on the trap or is of a markedly different color), provided the contestant does not fire at it- if the contestant fires, the result must be scored.

7.4 If the scorer announces, “No Target” for any contestant, the next contestant shall not shoot until the last contestant has shot and the scorer has ruled “Dead” or “Lost”.

7.5 It is the duty of the scorer to see that the shooters change posts at the proper time, however any targets that are shot after failure to move at the proper time will be scored.

7.6 A shooter is required to shoot the requisite number of targets from each post. If a shooter inadvertently skips a post, he/she or any other member of the squad will not be deemed out of turn but will be required to shoot the specified number of targets from the skipped post. While the shooter is shooting the skipped post, the remainder of the squad will remain behind the trap line and will not proceed to the next trap.

7.7 No member of a squad shall move toward the next post or leave the field until the squad member who is last has fired his/her final shot of the current posts' specified number of targets.

7.8 The official score sheet must be available for shooter inspection at all times.

7.9 It is an error if the referee/scorer fails to properly mark the results of any shot in the section of the score sheet where the results should be recorded. In such cases it is the duty of that contestant to have any error corrected before he/she has fired the first shot at the next post or in the case of his/her last post before leaving the trap. If the shooter fails to have the score corrected, the recorded score(s) shall remain unchanged, and no valid protest will be entertained.

7.10 Every contestant in a squad shall be permitted to examine his/her score before the sheet is sent to the bulletin board or to the cashier's office. The score sheet should be checked, confirmed, and initialed by each contestant. Each Contestant is encouraged to verify that any targets changed during a sub event are correctly noted as either dead or lost. After the completion of the last sub-event the score sheet will be handled as directed by shoot management.

7.11 Any protest concerning a score, or scores must be made before or immediately after the close of the competition to which such scores relate. A valid protest may only be made by a contestant who competed in the event.

ALL PROTESTS/CHALLENGES WILL BE HANDLED BY THE SHOOTING SPORTS ARENA DIRECTORS AND STAFF AND THEIR DECISIONS WILL BE FINAL. DISPUTES IN THESE EVENTS WILL BE RESOLVED BEFORE SCORES ARE POSTED. DISPUTES ARE NOT ELIGIBLE FOR EXECUTIVE COMMITTEE REVIEW AS THIS ACTIVITY IS NOT COUNTED TOWARDS TEAM OR ALL-AROUND POINTS.

8. DULY NOTIFIED

8.1 A contestant must be at the firing point within 3 minutes when it is time for their squad to shoot. Failure to do this may result in disqualification. The contestant is duly notified when their name has been called.

8.2 It shall be the shooter's responsibility to be present until the event is finalized by highest score or other agreed upon disposition.

8.2 If a contestant is involved in a tie-breaker for the event, it is the shooters responsibility to be ready when called to shoot. If the other tied contestants do respond, the missing contestant is deemed to have forfeited. 3 minutes will be allowed after the contestant's name is called for their squad before the shooter is disqualified.

9. FORMAT/TIE BREAKERS

NOTE: There is to be NO practice or test shots fired the day of the competition.

9.1 First Round. All contestants entered in the competition will be presented with 100 targets.

9.2 When all contestants have shot at 100 targets, Ties that exist in the first 10 places of the competition will participate in a shoot off.

9.6 Shoot off. Shoot offs will be conducted for any places 1st thru 10th that are tied. If there is no tie in 1st place, that shooter would be declared the winner of the event. If there is no tie in 2nd place, that shooter would be declared the Reserve Champion in the event and so on. Ties in the first 10 places will be shot off by presenting 10 targets to each contestant from the 20-yard line for the first tie-breaker. *If a tie still exists, shooters will shoot another 10 targets from the 23rd yard line to try to break the tie. If a tie still exists, shooters will shoot another 10 targets from the 27-yard line to try to break the tie. If a tie still exists, shooters will alternate shots from the 27-yard line on post 5 until the tie is broken.*

9.7 Protests or challenges should be voiced immediately after score cards are announced and must be done by the shooter or another shooting contestant. Scorer will verbally call “Lost” or “Dead” for each shot fired by each contestant. Disputes and/or protests for an individual shot must be voiced immediately.

SECTION 10. DRESS CODE FOR SHOOTING SPORTS EVENTS AT NATIONAL FINALS

Junior High and High School Events

These requirements are for competitors.

10.1 Shooting sports contestants **are required** to wear contestant/back numbers at all times. If they are not wearing their contestant/back number the contestant **WILL** be disqualified.

10.2 Jeans/long pants or trousers are required as are shirts and “closed toe” footwear (**Absolutely NO flip-flops, open toed shoes OR SHORTS are allowed.**)

10.3 T-Shirts with crew neck collars and sleeves may be worn. **ABSOLUTELY NO LOW CUT, CUT OFF, MIDRIFF OR TANK TOPS OF ANY KIND ARE ALLOWED.**

10.4 Any messages on clothing **MUST** be positive and cannot advertise alcohol or tobacco products.

10.5 Western boots and hats are optional during the competition. **Spurs are HIGHLY discouraged, and contestant may be asked to remove them at any time.**

10.6 Baseball caps are acceptable.

10.7 **Western attire must be worn when accepting awards during the year-end awards ceremony to include jeans, long sleeved shirts buttoned at the wrist, belt, boots and cowboy hat.**

Just a reminder: These events are outdoors, and, in most cases, there is little to no shelter. Please remember to bring plenty of water to stay hydrated. Portable shade such as umbrellas, visors or hats for spectators is recommended. Severe, inclement weather may cause delays or postponement.